



DESCRIPTION

The DS22W~DS220W are available in SOD-123FL package

ORDERING INFORMATION

Package Type	Part Number
SOD-123FL	DS22W
	DS24W
	DS26W
	DS28W
	DS210W
	DS212W
	DS215W
	DS220W
Note	SPQ: 3,000pcs/Reel
AiT provides all RoHS Compliant Products	

FEATURES

- Metal silicon junction, majority carrier conduction
- For surface mounted applications
- Low power loss, high efficiency
- High forward surge current capability
- For use in low voltage, high frequency inverters, free wheeling, and polarity protection applications
- Available in SOD-123FL package

PIN DESCRIPTION





ABSOLUTE MAXIMUM RATINGS AND ELECTRICAL CHARACTERISTICS

Ratings at 25°C ambient temperature unless otherwise specified. Single phase, half wave, 60Hz resistive or inductive load, for capacitive load, derate by 20 %

Parameter	Symbol	DS22W	DS24W	DS26W	DS28W	DS210W	DS212W	DS215W	DS220W	Unit
Maximum Repetitive Peak Reverse Voltage	V_{RRM}	20	40	60	80	100	120	150	200	V
Maximum RMS Voltage	V_{RMS}	14	28	42	56	80	100	105	140	V
Maximum DC Blocking Voltage	V_{DC}	20	40	60	80	100	120	150	200	V
Maximum Average Forward Rectified Current	$I_{F(AV)}$	2.0								A
Peak Forward Surge Current 8.3ms Single Half Sine-wave Superimposed on Rated Load (JEDEC Method)	I_{FSM}	50				40				A
Max Instantaneous Forward Voltage at 2A	V_F	0.55		0.70		0.85		0.95		V
Maximum DC Reverse Current at Rated DC Blocking Voltage	I_R	0.5 10				0.3 5				mA
Typical Junction Capacitance ^{NOTE1}	C_J	220		80						pF
Operating Junction Temperature Range	T_J	-55 ~ +125								°C
Storage Temperature Range	T_{STG}	-55 ~ +150								°C

NOTE1: Measured at 1MHz and applied reverse voltage of 4V D.C.



TYPICAL CHARACTERISTICS

Figure. 1 Forward Current Derating Curve

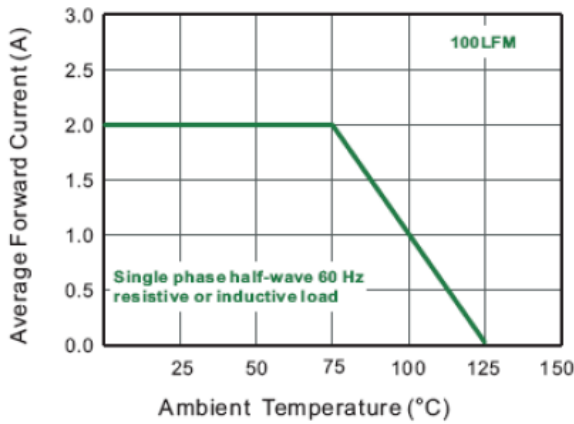

Figure. 2 Typical Reverse Characteristics

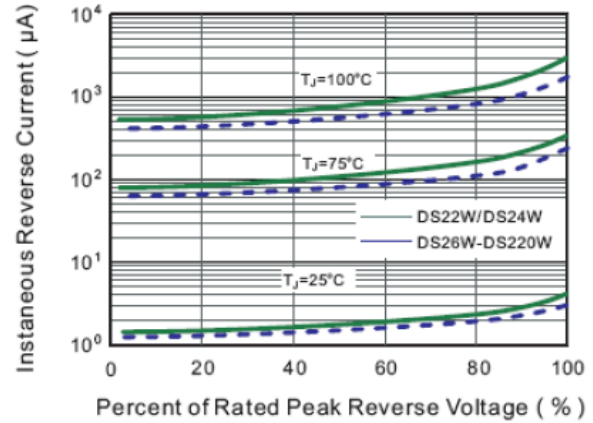

Figure. 3 Typical Forward Characteristic

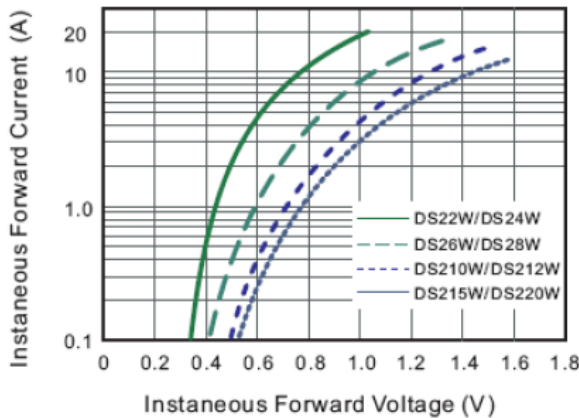

Figure. 4 Typical Junction Capacitance

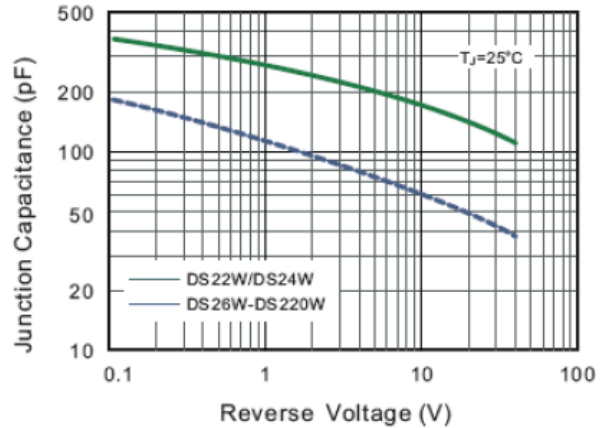
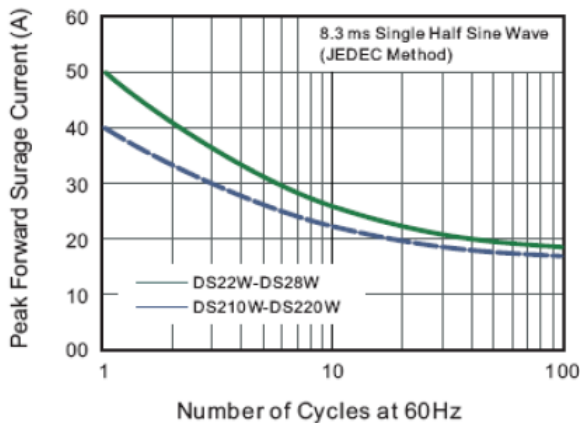
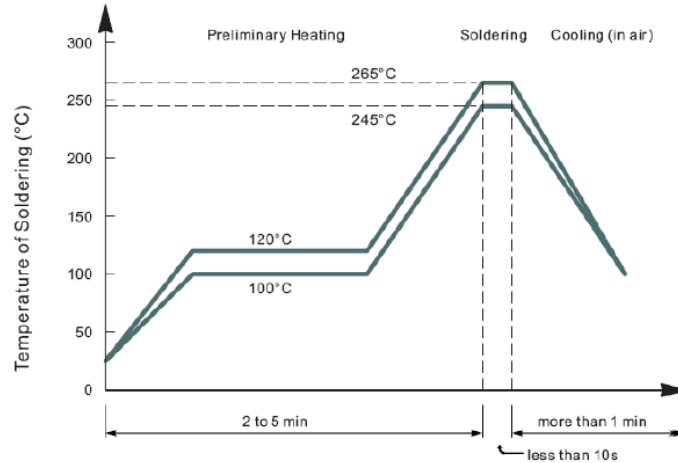

Figure. 5 Maximum Non-Repetitive Peak Forward Surge Current





Recommended condition of flow soldering



Recommended condition of reflow soldering

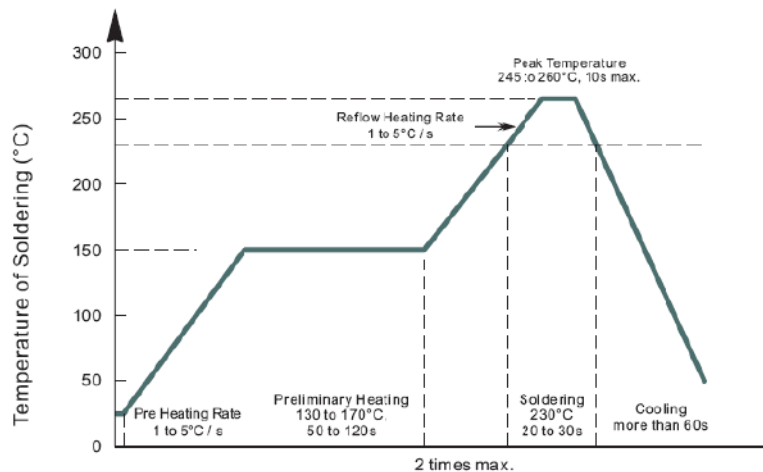

Recommended peak temperature is over 245°C. If peak temperature is below 245°C, you may adjust the following parameters; time length of peak temperature (longer), time length of soldering (longer), thickness of solder paste (thicker)

Condition of hand soldering

Temperature: 350°C

Time: 3s max.

Times: one time

Remark:

Lead free folder paste (96.5Sn/3.0Ag/0.5Cu)



PACKAGE INFORMATION

Dimension in SOD-123FL (Unit: mm)

Plastic surface mounted package; 2 leads

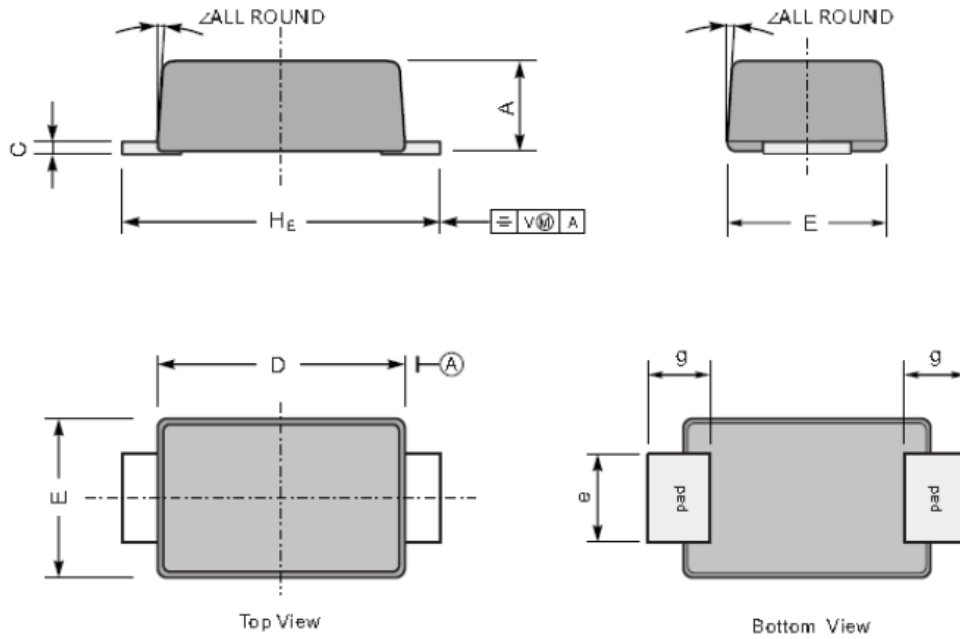

The recommended mounting pad size

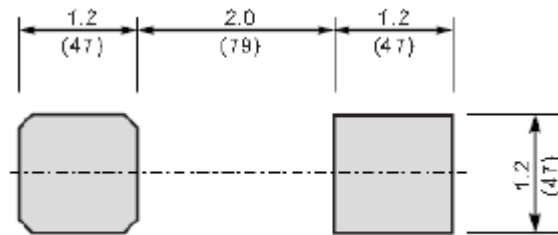

Unit: $\frac{\text{mm}}{\text{mil}}$

UNIT		A	C	D	E	e	g	H _E	∠
mm	Max	1.1	0.20	2.9	1.9	1.1	0.9	3.8	7°
	Min	0.9	0.12	2.6	1.7	0.8	0.7	3.5	
mil	Max	43	7.9	114	75	43	35	150	
	Min	35	4.7	102	67	31	23	138	



IMPORTANT NOTICE

AiT Semiconductor Inc. (AiT) reserves the right to make changes to any its product, specifications, to discontinue any integrated circuit product or service without notice, and advises its customers to obtain the latest version of relevant information to verify, before placing orders, that the information being relied on is current.

AiT Semiconductor Inc.'s integrated circuit products are not designed, intended, authorized, or warranted to be suitable for use in life support applications, devices or systems or other critical applications. Use of AiT products in such applications is understood to be fully at the risk of the customer. As used herein may involve potential risks of death, personal injury, or severe property, or environmental damage. In order to minimize risks associated with the customer's applications, the customer should provide adequate design and operating safeguards.

AiT Semiconductor Inc. assumes to no liability to customer product design or application support. AiT warrants the performance of its products of the specifications applicable at the time of sale.